

# Digital Transmission

# DIGITAL-TO-DIGITAL CONVERSION

*In this section, we see how we can represent digital data by using digital signals. The conversion involves three techniques: **line coding**, **block coding**, and **scrambling**. Line coding is always needed; block coding and scrambling may or may not be needed.*

## *Topics discussed in this section:*

- **Line Coding**
- **Line Coding Schemes**
- **Block Coding**
- **Scrambling**

# Line Coding

- Converting a string of 1's and 0's (digital data) into a sequence of signals that denote the 1's and 0's.
- For example a high voltage level (+V) could represent a "1" and a low voltage level (0 or -V) could represent a "0".

---

# *Line coding and decoding*

---

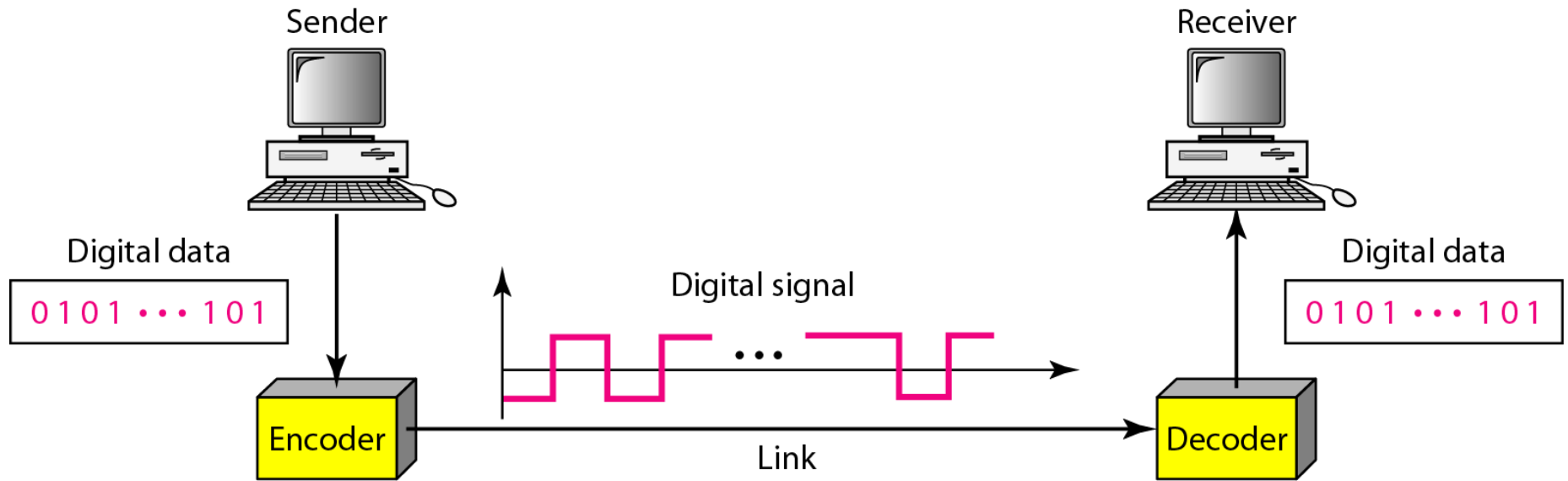

# Mapping Data symbols onto Signal levels

- A data symbol (or element) can consist of a number of data bits:
  - 1, 0 or
  - 11, 10, 01, .....
- A data symbol can be coded into a single signal element or multiple signal elements
  - 1  $\rightarrow$   $+V$ , 0  $\rightarrow$   $-V$
  - 1  $\rightarrow$   $+V$  and  $-V$ , 0  $\rightarrow$   $-V$  and  $+V$
- The ratio 'r' is the number of data elements carried by a signal element.

# Relationship between data rate and signal rate

- The data rate defines the number of bits sent per sec - bps. It is often referred to the bit rate.
- The signal rate is the number of signal elements sent in a second and is measured in bauds. It is also referred to as the modulation rate.
- Goal is to increase the data rate whilst reducing the baud rate.

# Signal element versus data element

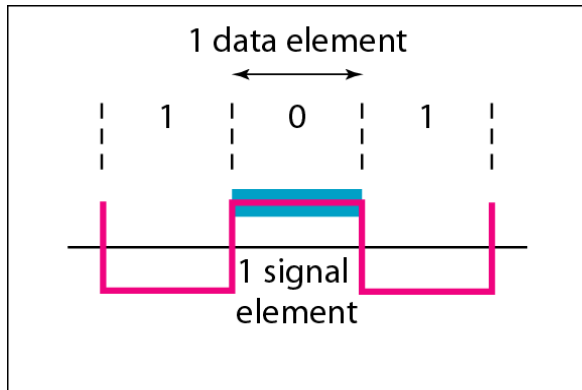

a. One data element per one signal element ( $r = 1$ )

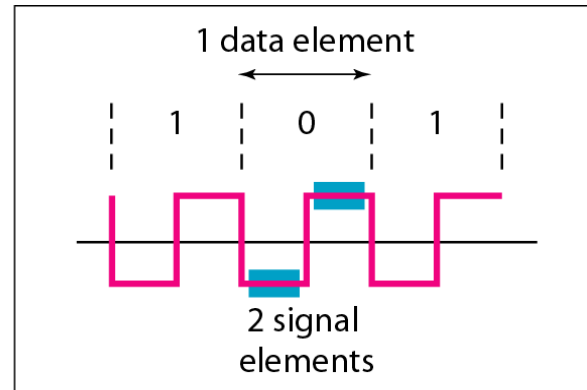

b. One data element per two signal elements ( $r = \frac{1}{2}$ )

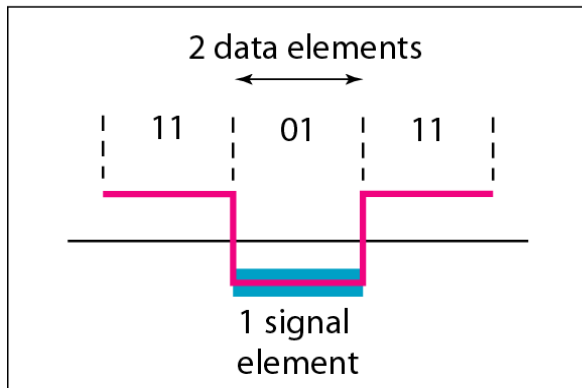

c. Two data elements per one signal element ( $r = 2$ )

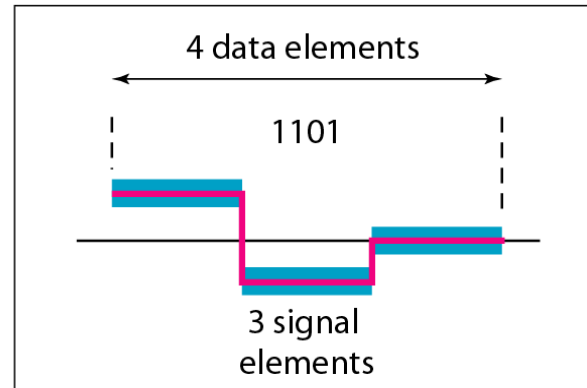

d. Four data elements per three signal elements ( $r = \frac{4}{3}$ )

# Data rate and Baud rate

- The baud or signal rate can be expressed as:

$$S = c \times N \times 1/r \text{ bauds}$$

where N is data rate

c is the case factor (worst, best & avg.)

r is the ratio between data element & signal element



## *Example 1*

*A signal is carrying data in which one data element is encoded as one signal element ( $r = 1$ ). If the bit rate is 100 kbps, what is the average value of the baud rate if  $c$  is between 0 and 1?*

### *Solution*

*We assume that the average value of  $c$  is  $1/2$ . The baud rate is then*

$$S = c \times N \times \frac{1}{r} = \frac{1}{2} \times 100,000 \times \frac{1}{1} = 50,000 = 50 \text{ kbaud}$$



*Note*

**Although the actual bandwidth of a digital signal is infinite, the effective bandwidth is finite.**

## *Example 2*

*The maximum data rate of a channel (see Chapter 3) is  $N_{max} = 2 \times B \times \log_2 L$  (defined by the Nyquist formula). Does this agree with the previous formula for  $N_{max}$ ?*

### *Solution*

*A signal with  $L$  levels actually can carry  $\log_2 L$  bits per level. If each level corresponds to one signal element and we assume the average case ( $c = 1/2$ ), then we have*

$$N_{max} = \frac{1}{c} \times B \times r = 2 \times B \times \log_2 L$$

# Considerations for choosing a good signal element referred to as line encoding

- **Baseline wandering** - a receiver will evaluate the average power of the received signal (called the baseline) and use that to determine the value of the incoming data elements. If the incoming signal does not vary over a long period of time, the baseline will drift and thus cause errors in detection of incoming data elements.
- A good line encoding scheme will prevent long runs of fixed amplitude.

# Line encoding C/Cs

- **DC components** - when the voltage level remains constant for long periods of time, there is an increase in the low frequencies of the signal. Most channels are bandpass and may not support the low frequencies.
- This will require the removal of the dc component of a transmitted signal.

# Line encoding C/Cs

- **Self synchronization** - the clocks at the sender and the receiver must have the same bit interval.
- If the receiver clock is faster or slower it will misinterpret the incoming bit stream.

---

## *Effect of lack of synchronization*

---

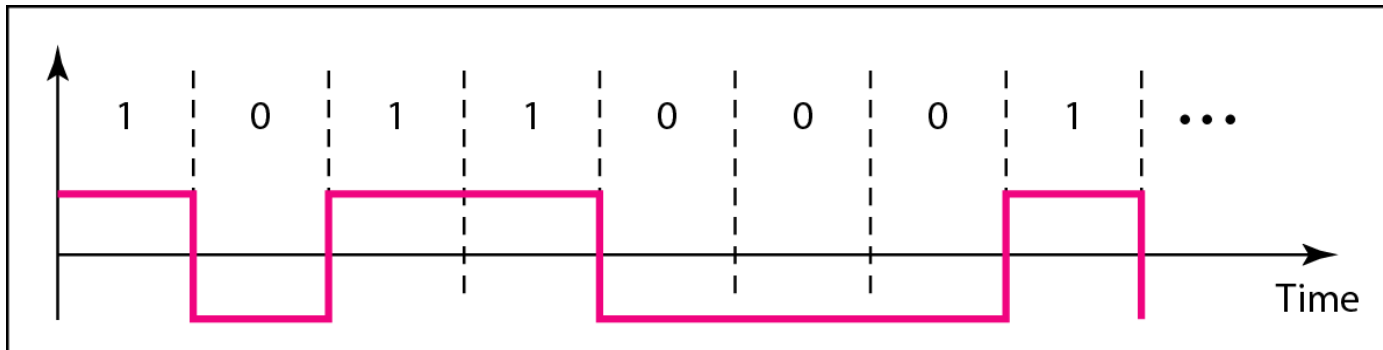

a. Sent

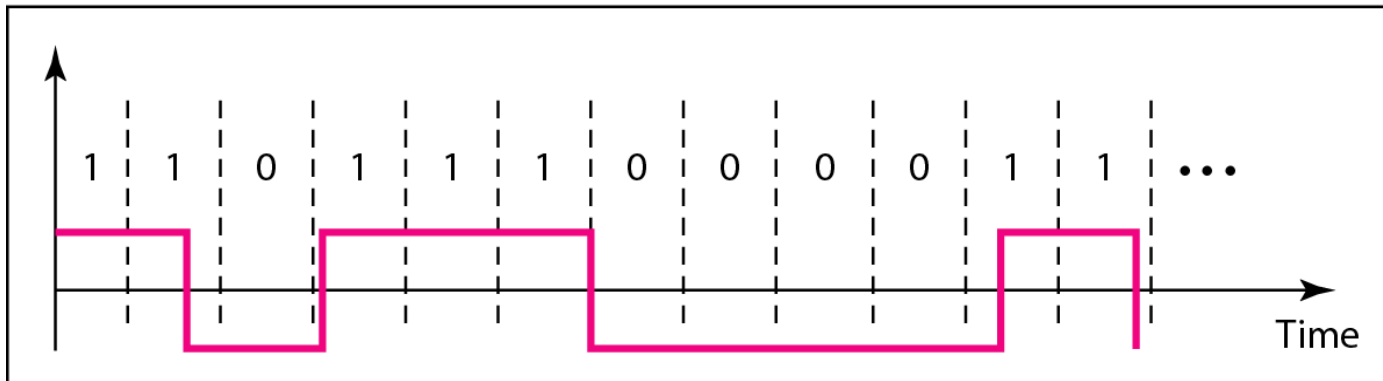

b. Received

### *Example 3*

*In a digital transmission, the receiver clock is 0.1 percent faster than the sender clock. How many extra bits per second does the receiver receive if the data rate is*

*1 kbps? How many if the data rate is 1 Mbps?*

*At 1 kbps, the receiver receives 1001 bps instead of 1000 bps.*

1000 bits sent

1001 bits received

1 extra bps

*At 1 Mbps, the receiver receives 1,001,000 bps instead of 1,000,000 bps.*

1,000,000 bits sent

1,001,000 bits received

1000 extra bps



# Line encoding C/Cs

- Error detection - errors occur during transmission due to line impairments.
- Some codes are constructed such that when an error occurs it can be detected. For example: a particular signal transition is not part of the code. When it occurs, the receiver will know that a symbol error has occurred.

# Line encoding C/Cs

- Noise and interference - there are line encoding techniques that make the transmitted signal "immune" to noise and interference.
- This means that the signal cannot be corrupted, it is stronger than error detection.

# Line encoding C/Cs

- Complexity - the more robust and resilient the code, the more complex it is to implement and the price is often paid in baud rate or required bandwidth.

---

# *Line coding schemes*

---

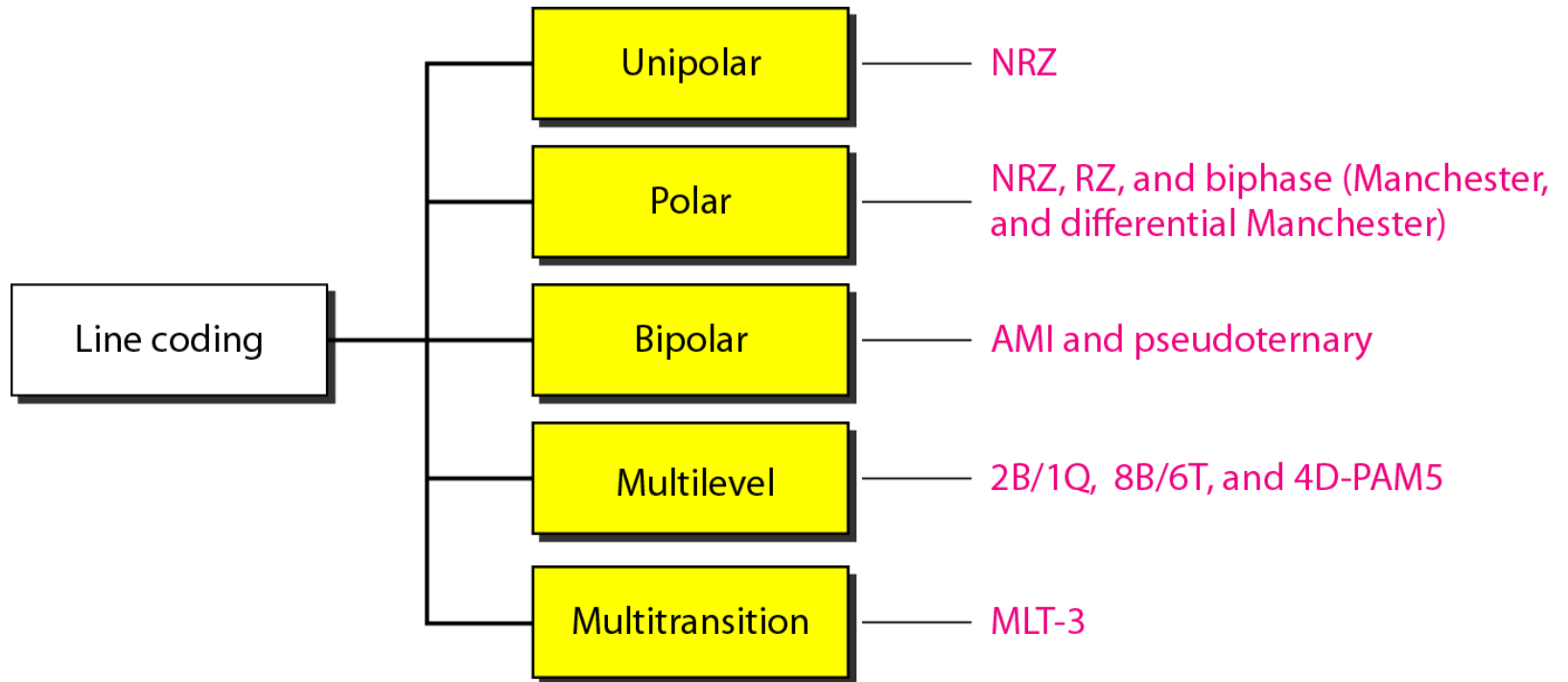

# Unipolar

- All signal levels are on one side of the time axis - either above or below
- NRZ - Non Return to Zero scheme is an example of this code. The signal level does not return to zero during a symbol transmission.
- Scheme is prone to baseline wandering and DC components. It has no synchronization or any error detection. It is simple but costly in power consumption.

---

## *Unipolar NRZ scheme*

---

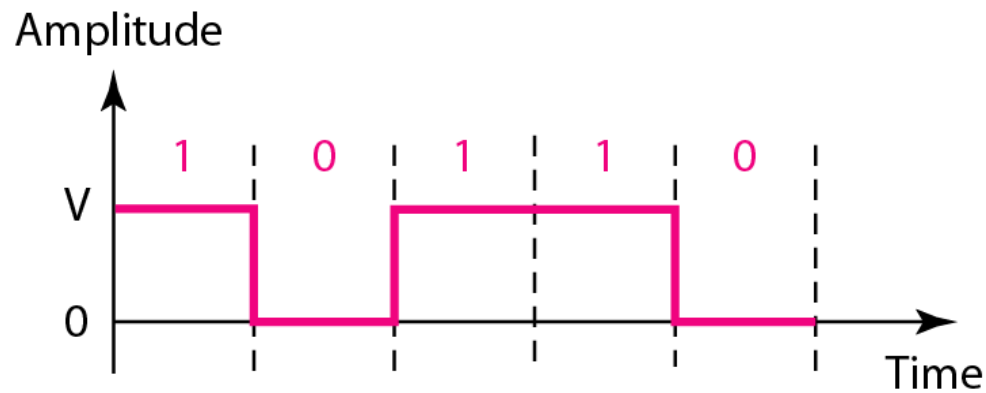

$$\frac{1}{2}V^2 + \frac{1}{2}(0)^2 = \frac{1}{2}V^2$$

Normalized power

# Polar - NRZ

- The voltages are on both sides of the time axis.
- Polar NRZ scheme can be implemented with two voltages. E.g.  $+V$  for 1 and  $-V$  for 0.
- There are two versions:
  - NZR - Level (NRZ-L) - positive voltage for one symbol and negative for the other
  - NRZ - Inversion (NRZ-I) - the change or lack of change in polarity determines the value of a symbol. E.g. a "1" symbol inverts the polarity a "0" does not.

# Polar NRZ-L and NRZ-I schemes

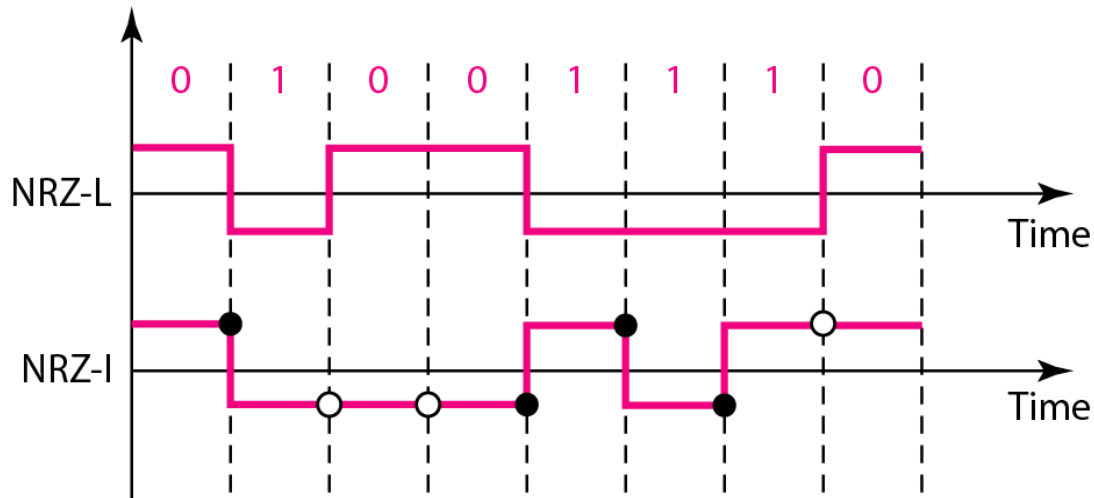

○ No inversion: Next bit is 0      ● Inversion: Next bit is 1

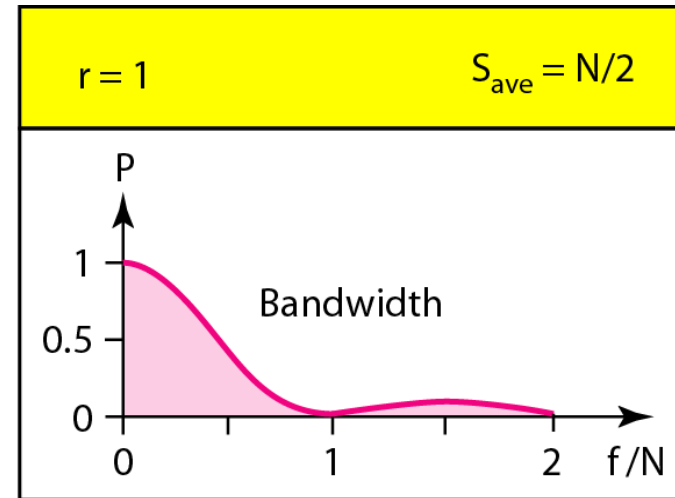





*Note*

**In NRZ-L the level of the voltage determines the value of the bit.**

**In NRZ-I the inversion or the lack of inversion determines the value of the bit.**



*Note*

**NRZ-L and NRZ-I both have an average  
signal rate of  $N/2$  Bd.**



*Note*

**NRZ-L and NRZ-I both have a DC component problem and baseline wandering, it is worse for NRZ-L. Both have no self synchronization & no error detection. Both are relatively simple to implement.**

## ***Example 4***

***A system is using NRZ-I to transfer 1-Mbps data. What are the average signal rate and minimum bandwidth?***

### ***Solution***

***The average signal rate is  $S = c \times N \times R = 1/2 \times N \times 1 = 500$  kbaud. The minimum bandwidth for this average baud rate is  $B_{min} = S = 500$  kHz.***

***Note  $c = 1/2$  for the avg. case as worst case is 1 and best case is 0***

# Polar - RZ

- The Return to Zero (RZ) scheme uses three voltage values. +, 0, -.
- Each symbol has a transition in the middle. Either from high to zero or from low to zero.
- This scheme has more signal transitions (two per symbol) and therefore requires a wider bandwidth.
- No DC components or baseline wandering.
- Self synchronization - transition indicates symbol value.
- More complex as it uses three voltage level. It has no error detection capability.

# *Polar RZ scheme*

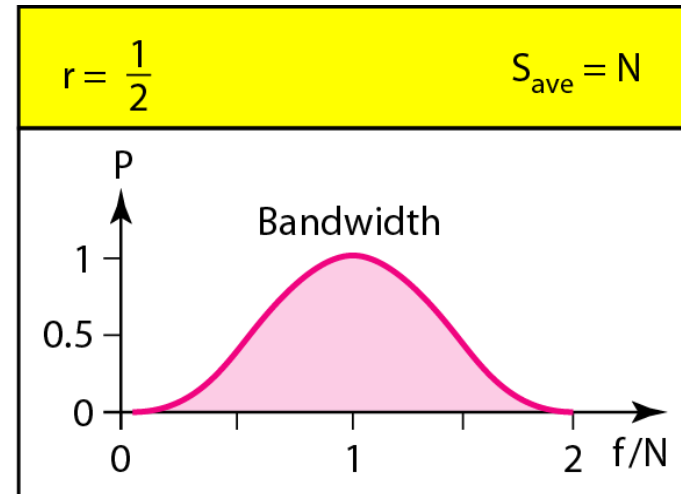
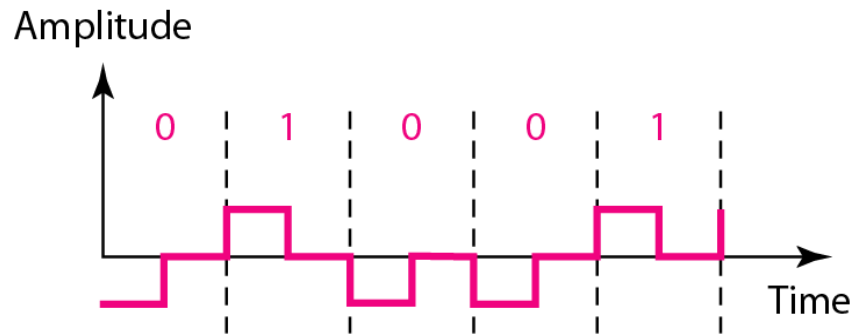

# Polar - Biphase: Manchester and Differential Manchester

- **Manchester** coding consists of combining the NRZ-L and RZ schemes.
  - Every symbol has a level transition in the middle: from high to low or low to high. Uses only two voltage levels.
- **Differential Manchester** coding consists of combining the NRZ-I and RZ schemes.
  - Every symbol has a level transition in the middle. But the level at the beginning of the symbol is determined by the symbol value. One symbol causes a level change the other does not.

# *Polar biphasic: Manchester and differential Manchester schemes*

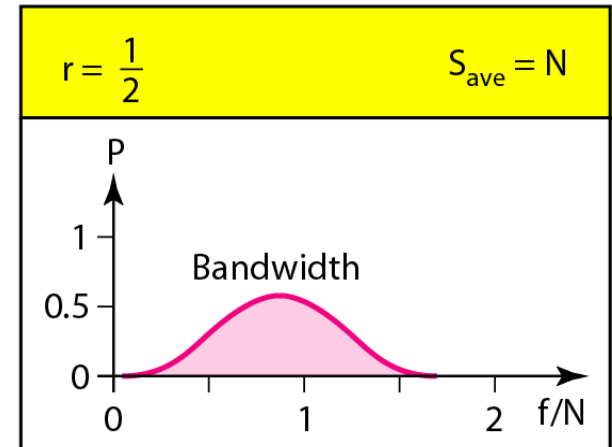
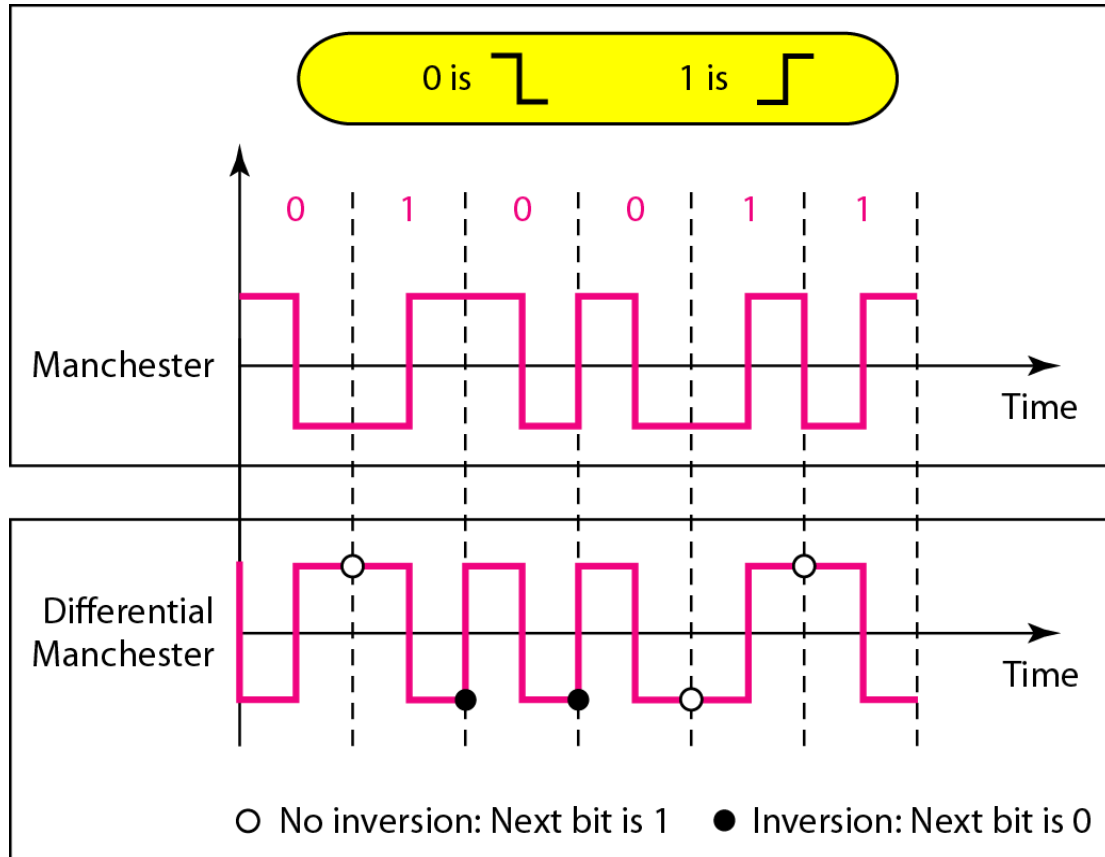





---

*Note*

**In Manchester and differential Manchester encoding, the transition at the middle of the bit is used for synchronization.**



*Note*

**The minimum bandwidth of Manchester and differential Manchester is 2 times that of NRZ. There is no DC component and no baseline wandering. None of these codes has error detection.**

# Bipolar - AMI and Pseudoternary

- Code uses 3 voltage levels:  $+V$ ,  $0$ ,  $-V$ , to represent the symbols (note not transitions to zero as in RZ).
- Voltage level for one symbol is at  $0$  and the other alternates between  $+V$  &  $-V$ .
- Bipolar Alternate Mark Inversion (AMI) - the  $0$  symbol is represented by zero voltage and the  $1$  symbol alternates between  $+V$  and  $-V$ .
- Pseudoternary is the reverse of AMI.

# *Bipolar schemes: AMI and pseudo ternary*

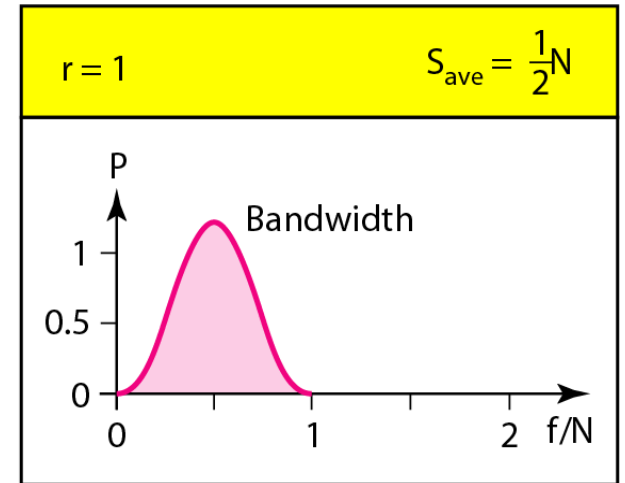
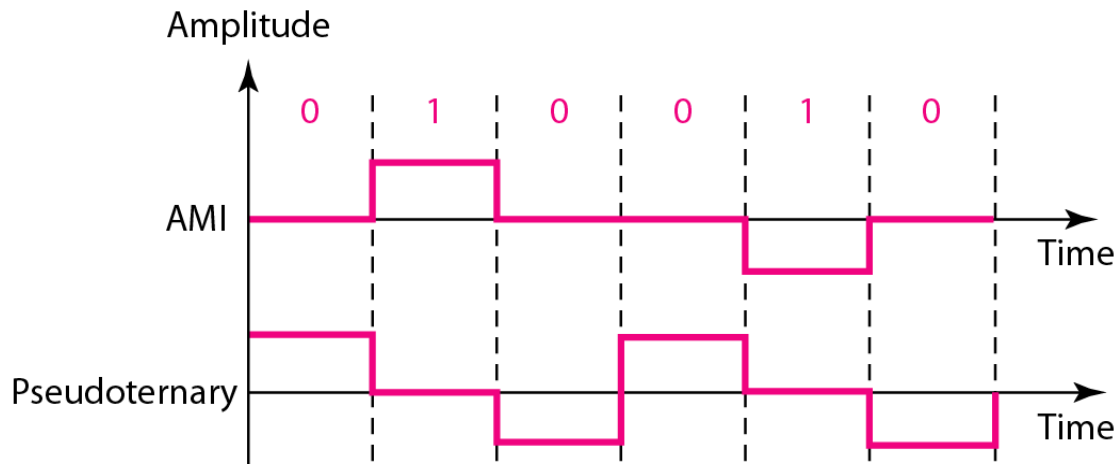

# Bipolar C/Cs

- It is a better alternative to NRZ.
- Has no DC component or baseline wandering.
- Has no self synchronization because long runs of "0"s results in no signal transitions.
- No error detection.